

**Multi-CF™ UHV Spherical Decagon:  
 Vacuum Chamber with 8.0” and 2.75” CF Ports**

**FOR USE IN:**

- Compact UHV vacuum chambers
- Portable low-cost UHV systems
- High-complexity UHV subsystems
- UHV Specimen Transfer systems
- General UHV Vacuum Plumbing

**FEATURES / OPTIONS:**

- Easy access UHV Chamber
- Multiple CF sealing surfaces (8.0” and 2.75”) cut on a hollow sphere
- Annular port Grabber Grooves on all sealing ports for internal mounting.
- Unitary stainless steel 316L construction. Titanium custom also available
- No welds, no inside corners, highly polished
- Precise Port Alignment (<0.1 degrees)



*Spherical Decagon Multi-CF™ UHV Vacuum Chamber  
 MCF600-SphDecagon-G2C10 with (2) 8.0” and (10) 2.75”  
 CF Sealing Surface Ports*

**Multi-CF™ Spherical Dodecagon**

The Spherical Decagon Multi-CF™ UHV vacuum chambers are based on a design of two main or primary CF sealing surface ports that are parallel and offset sections cut through a global hollow spherical form. A secondary series of ten (10) CF sealing surface ports are positioned in a plane perpendicular to the main surfaces and provides an equally spaced polygon array of ports in the form of a *decagon*. These designs are precision CNC fabricated from a single piece of 316L Stainless Steel. The option of using various Titanium alloys is also available custom.

The Kimball Physics *MCF800-SphDecagon-G2C12* is a twelve (12) port compact UHV vacuum chamber with two (2) 8.0” (G) main sealing surfaces and ten (10) 2.75” (C) CF secondary sealing surfaces. All ports have internal annular Grabber Grooves that enable stable internal mounting of fixtures, devices and apparatus. [Groove Grabber clamps](#) are available from Kimball Physics.

Please reach out to Kimball Physics to engage our specialists if you need a custom system for your specific application.

	<b>MCF800-SphDec-G2C10</b>
Multi-CF™ Fitting	Spherical Decagon
COMMON APPLICATION	Small UHV Vacuum Chamber
CONSTRUCTION / MATERIAL	Unitary Stainless Steel 316L (Titanium available as option)
2.75” CF SEALING SURFACES	Ten(10) CF (C) Sealing Surfaces with (12) 1/4-28 tapped bolt holes, plus one triplet of Grabber Grooves (internal annular grooves) per sealing surface
8.0” CF SEALING SURFACES	Two (2) CF (G) Sealing Surfaces with (40) 5/16-24 tapped bolt holes, plus one triplet of Grabber Grooves (internal annular grooves) per sealing surface
EXTERNAL MOUNTING	External Mounting options are available utilizing port flanges. Please see Flange Adapters on Kimball Physics website.
INTERNAL WORKSPACE	Internal Volume: 131.1 in3 (2149 cc) Spherical ID: 7.38” in (187.33 mm)
WEIGHT	16.63 lbs (7.54 kg)

All Dimensions are in inches.  
(Millimeters are in parentheses)

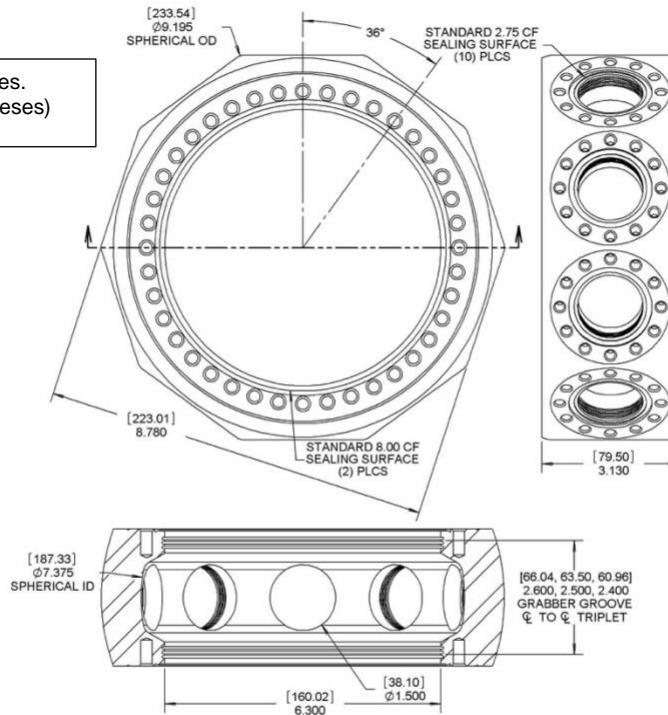

## MCF800-SphDec-G2C10

### References

For more information about Multi-Port CF (MCF) Vacuum Chambers and Accessories, visit our website at: [Multi-CF Hardware \(MCF™ Hardware and Accessories\)](http://www.kimballphysics.com)

#### Other References:

- MCF Vacuum Chambers Overview (Vacuum Chambers and Accessories)
- Spherical Octagon- Multi-CF Hardware
- Spherical Cube- Multi-CF Hardware
- Spherical Cube Expanded- Multi-CF Hardware
- Spherical Hexagon- Multi-CF Hardware
- Thin Flange- Multi-CF Hardware
- Close Coupler (non-rotatable)- Multi-CF Hardware

#### Notes:

##### 1. Cautions:

- Silver Plated Bolts or Equivalent Lubrication must be used.
  - Please measure the hole depth and other flange / copper ring /part thicknesses
  - Choose a correct bolt length such that the bolt doesn't bottom in the tapped hole prior to tightening the structure.
2. 3D Solid Models of all parts shown are available as STEP files.  
They can be downloaded from Kimball Physics Website for interactive visualization and measurements in your CAD software environment.
3. Specifications Subject to Change Without Notice.
4. Images are not to scale
5. DE Altobelli, DT Taylor 2/22/2023

Document MCF\_Spherical\_Decagon\_2023\_0222  
COPYRIGHT KIMBALL PHYSICS 2023, ALL RIGHTS RESERVED